

STATUS SCIENTIFIC CONTROLS

PROGRAMMABLE

FIXED SYSTEM FOR GAS AND SAFETY MONITORING AND CONTROL 



FGD3 FLAMMABLE GAS DETECTOR HEAD

Technical Data Sheet



Features

- LCD readout
- 4 to 20 milliamp output
- pushbutton calibration
- green flashing 'confidence' LED
- integral sensor for cost sensitive applications
- intrinsically safe
- water and dust proof to IP66
- RFI protected

Specification

Size	122 x 122 x 75mm nominal
Weight	0.65Kg
Gas Types	Flammable, Fuels
Operating Voltage	7 to 30vdc (for 4 to 20 mA signal) 4 to 7vdc (for pellistor supply)
Cable	3 core (plus screen)
Output Signal	0mA - open circuit 2mA - fault 4mA - zero gas 20mA - full scale gas 22mA - over-range
Max. Cable Loop Resistance	Signal - 560 ohms at 24vdc Sensor - 19 ohms at 7.5vdc
Sensor Type	Pellistor (catalytic bead)
Measurement range	0-100% LEL (5% vol CH ₄), Ammonia (0-50% LEL or 0-10% LEL)
Response Time	T ₉₀ < 10 sec (Methane)

Specification

Measurement Resolution	1% LEL
Operating Temperature	- 20 to +40 deg.C
Humidity Range	0 to 95% RH non-condensing
Operating Pressure	Ambient + or - 10%
Typical Alarm Levels (these are set up in the associated control unit)	Level 1 - 20% LEL Level 2 - 40% LEL Level 3 - 60% LEL

European Hazardous Area Certification

Standards	EN50014:1997 + Amd's 1 & 2 EN50018:2000 EN50020:1994
ATEX Certificate No.	BAS 01ATEX2300
Certification Coding	 II 2 G EEx iad IIC T4 (-20 ^o C<Ta<+60 ^o C)
Zones	1 & 2

Ordering Details (add suffix '-US' for USA)

Stock No.	Description
SS415	FGD3 Flammable (0-100% vol) Detector Head
SS416	FGD3 Flammable (0-100% LEL) Detector Head
SS417	FGD3 Flammable (0-100% LEL) Detector Head for Fuels

**Note – Standard gland entry is 20mm x 1.5mm pitch thread.
For USA and Canada, gland entry is 1/2" NPT thread.**

Mounting Details

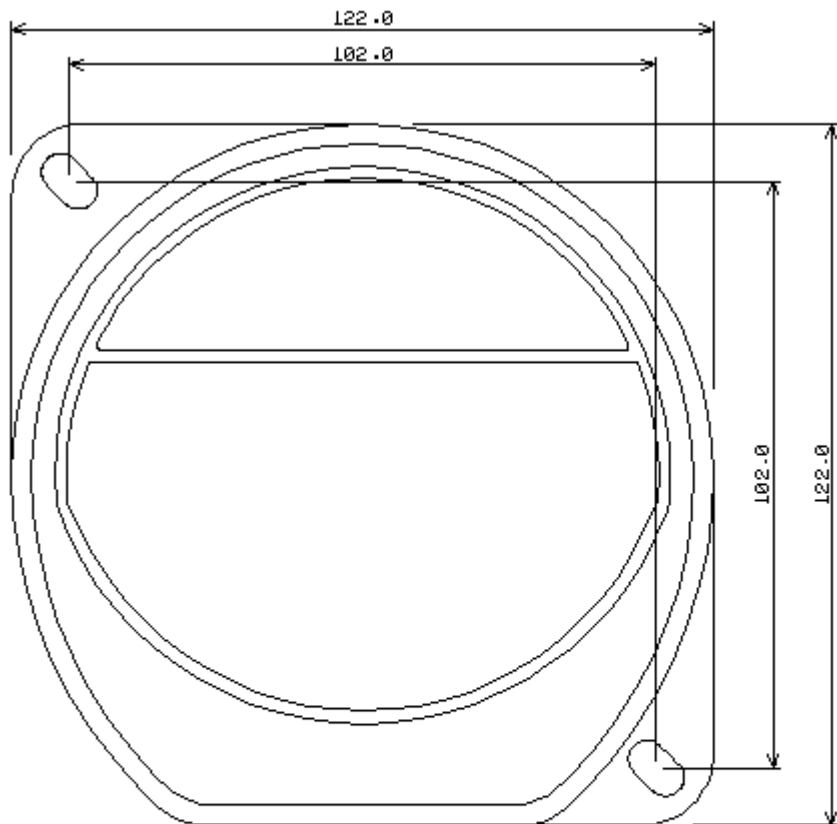

Designed and Manufactured in the UK

Status Scientific Controls Ltd
Hermitage Lane Industrial Estate
Kings Mill Way, Mansfield
Nottinghamshire NG18 5ER
Tel: (44) 01623 651381 Fax: (44) 01623 427816
e-mail: sales@status-scientific.com
www.status-scientific.com